



Cooling more drinks, with less energy.

Introducing the **CED 600** with the latest technology for energy savings and sustainability, with the flexibility to offer carbonated and non-carbonated beverages.

Features

- › R290 refrigerant
- › Fully louvered top provides air circulation for more efficient operation
- › Stainless steel construction
- › Key lock switch
- › Electronic ice bank control
- › Removable refrigeration deck for ease of service
- › 3-way back block

Options

- › Leg kit
- › External / Internal cold carbonation
- › Internal mini syrup pumps
- › Shrouded merchandiser (Unlit / LED)

Certified by these agencies:



CUSTOMER SERVICE

Should you require more information about our products, please do not hesitate to contact our customer service team at custserv@lancerworldwide.com.



WARRANTY

For warranty specifics by product, contact your Lancer® Sales Representative. Equipment design and/or specifications are subject to change without notice.

For more information visit lancerworldwide.com or call 1-800-729-1500

6655 Lancer Boulevard • San Antonio, TX 78219 • 210-310-7000 • Fax: 210-310-7250 • © 2024 Lancer® Worldwide • CED 600 12/24

CED 600 with optional shrouded merchandiser

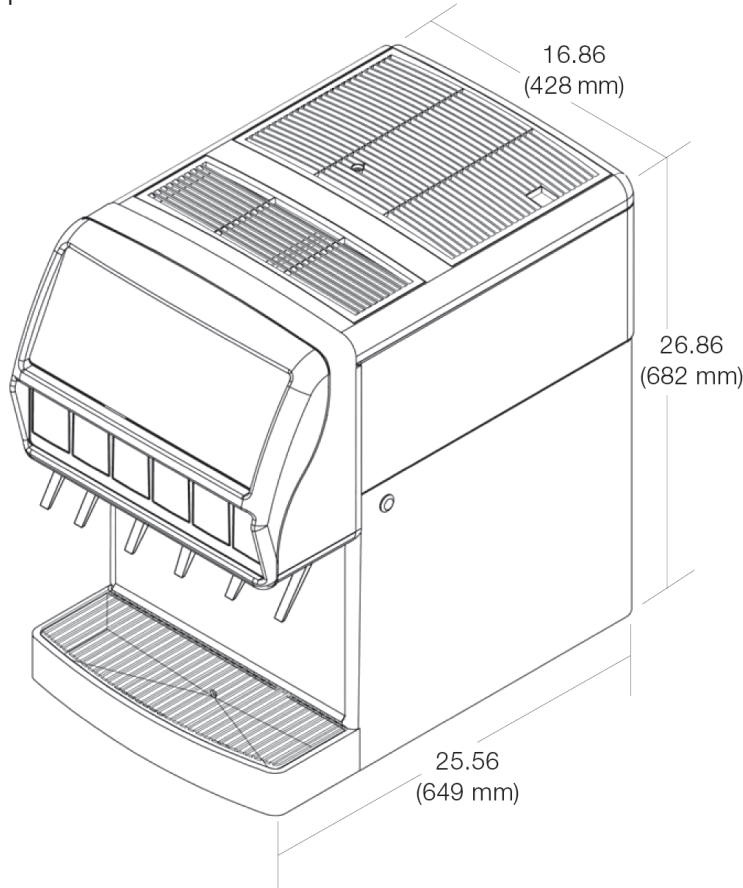

One-Touch Flexible Carb to Non-Carb Dispensing



Dimensions

26.86" H x 16.86" W x 25.56" D
(682 mm H x 428 mm W x 649 mm D)

Electrical

115V/60Hz, 8 Amps
230V/50Hz, 4 Amps

Compressor

1/3 HP

Weight

Ambient Carb: Empty: 111 lbs (50 kg)
Operating: 185 lbs (84 kg)
Shipping: 131 lbs (60 kg)
Cold Carb: Empty: 134 lbs (61 kg)
Operating: 195 lbs (88.5 kg)
Shipping: 154 lbs (70 kg)

Ice Bank Weight

20 lbs (9 kg)

Fittings

Carbonated Water Inlet: 3/8"(9.5 mm) male flare (Ambient Carb)
Plain Water inlet: 3/8"(9.5 mm) male barb
Syrup inlets: 1/4"(6.35 mm) male barb
CO2 inlet: 1/4" (6.35 mm) male barb (Cold Carb)

For more information visit lancerworldwide.com or call 1-800-729-1500

6655 Lancer Boulevard • San Antonio, TX 78219 • 210-310-7000 • Fax: 210-310-7250 • © 2024 Lancer® Worldwide • CED 600 12/24

"Lancer" and "Lancer Worldwide" are trademarks of Lancer Corp. © 2024 by Lancer®, all rights reserved.