



## Cooling more drinks, with less energy.

Introducing the **CED 800** with the latest technology for energy savings and sustainability, with the flexibility to offer carbonated and non-carbonated beverages.

### Features

- › R290 refrigerant
- › Reduced energy consumption
- › Eco-Smart cooling™
- › Available with 6 or 8 post mix valves
- › Flexible manifold configuration
- › Removable refrigeration deck for ease of service
- › Stainless steel construction
- › Added louvers for ventilation
- › 3/4 HP compressor
- › 3-way back block

### Options

- › Leg kit
- › External / Internal cold carbonation
- › Internal mini syrup pumps

Certified by these agencies:



#### CUSTOMER SERVICE

Should you require more information about our products, please do not hesitate to contact our customer service team at [custserv@lancerworldwide.com](mailto:custserv@lancerworldwide.com).



#### WARRANTY

For warranty specifics by product, contact your Lancer® Sales Representative. Equipment design and/or specifications are subject to change without notice.



**One-Touch Flexible Carb to Non-Carb Dispensing**

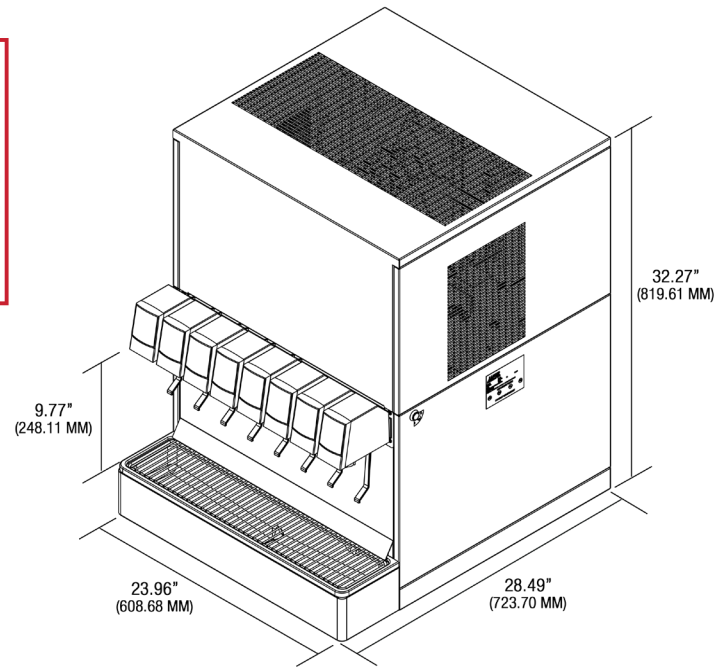
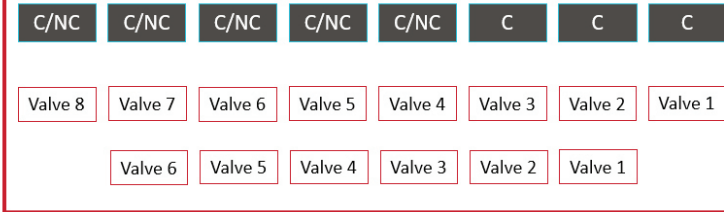

**Dimensions**

32.27" H x 23.96" W x 28.49" D  
(819.61 mm H x 608.68 mm W x 723.70 mm D)

**Electrical**

115V/60Hz, 12 Amps  
220V/50Hz, 7.5 Amps  
220V/60Hz, 8 Amps

**Compressor**

3/4 HP

**Weight**

Ambient Carb: Empty: 205 lbs (93 kg)  
Operating: 355 lbs (161 kg)  
Shipping: 245 lbs (111 kg)  
Cold Carb: Empty: 220 lbs (99.8 kg)  
Operating: 386 lbs (175 kg)  
Shipping: 267 lbs (121 kg)

**Ice Bank Weight**

50 lbs (23 kg)

**Fittings**

Carbonated Water Inlet: 3/8"(9.5 mm) male flare (Ambient Carb)  
Plain Water inlet: 3/8"(9.5 mm) male barb  
Syrup inlets: 3/8"(9.5 mm) male barb  
CO2 inlet: 1/4" (6.35 mm) male barb (Cold Carb)

For more information visit [lancerworldwide.com](http://lancerworldwide.com) or call 1-800-729-1500

6655 Lancer Boulevard • San Antonio, TX 78219 • 210-310-7000 • Fax: 210-310-7250 • © 2024 Lancer® Worldwide • CED 800 12/24

"Lancer" and "Lancer Worldwide" are trademarks of Lancer Corp. © 2024 by Lancer®, all rights reserved.