

IBD 60



Accessories and Options

Ice Maker Compatibility

- › Accepts 22", 25", 30" & 44" wide ice makers (adapters may be required)
- › Manual front load tee chute
- › Variable automatic agitation timer

Certified by these agencies:



CUSTOMER SERVICE

Should you require more information about our products, please do not hesitate to contact our customer service team at custserv@lancerworldwide.com.

The **IBD** is Lancer's #1 selling self-serve dispenser. Hard plumbed syrup and water lines deliver excellent icy cold drinks. Versatile valve configurations and a portion control option allow for easy beverage cost monitoring. Topped with a compelling wraparound display, the IBD is a favorite.

Features

- › Illuminated interchangeable front graphics
- › High capacity ice storage bin
- › Stainless steel construction; exterior and interior
- › High capacity drip tray helps avoid safety hazards and drink station cleanup from spills
- › Unique hex drive ice agitation and dispense drive system
- › Multiple valve configurations available for self-serve and portion control operation
- › Fully insulated storage bin and drip tray to control condensation
- › Front and rear plumbing access for installation flexibility
- › LEV® valves standard, other valves available upon request
- › Key lock switch



WARRANTY

For warranty specifics by product, contact your Lancer™ Sales Representative. Equipment design and/or specifications are subject to change without notice.

For more information visit lancerworldwide.com or call 1-800-729-1500

6655 Lancer Boulevard • San Antonio, TX 78219 • 210-310-7000 • Fax: 210-310-7250 • © 2024 Lancer™ Worldwide • IBD 60 03/24

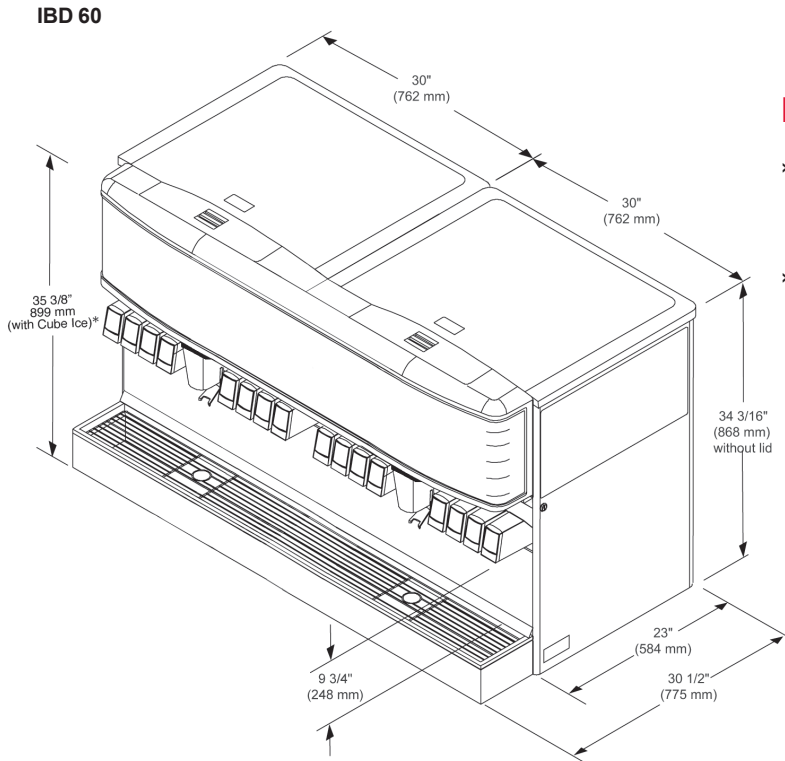

Distinctive Design

- › **IBD 60** - 16 valves (3-1-1-3-3-1-1-3)
 - Two ice chutes
- › **IBD 60** - 20 valves ((3-1-1-3-3-1-1-3))
 - Two ice chutes

Dimensions

IBD 60 - 35.375" H x 60.75" W x 30.5" D
(899 mm H x 1543 mm W x 775 mm D)

Space Required

IBD 60 - 62.75" W x 31.5" D - (1594mm W x 800 mm D)

Height: *Allow sufficient clearance for manually filling with ice or refer to ice maker recommendation for top clearance.*

Fittings for all

Syrup inlets: 3/8" (9.5 mm) male barb

Soda inlets: 3/8" (9.5 mm) male barb

Weight

IBD 60 - With Ice: 760 lbs (345kg) - Shipping: 460 lbs (209kg)

Ice Bank Weight

IBD 60 - Capacity: 500 lbs (227kg) - Dispensable: 350 lbs (159kg)

Electrical

IBD 60 - 115V/60Hz, 6 Amps - 230V/50Hz, 3 Amps

For more information visit lancerworldwide.com or call 1-800-729-1500

6655 Lancer Boulevard • San Antonio, TX 78219 • 210-310-7000 • Fax: 210-310-7250 • © 2024 Lancer™ Worldwide • IBD 60 03/24

"Lancer" and "Lancer Worldwide" are trademarks of Lancer Corp. © 2024 by Lancer™, all rights reserved.