

# INSTALLATION INSTRUCTIONS

## ICE COOLED DISPENSER

### FOR ONE PIECE 23" PLUG-IN DRIP TRAY

#### 1. INSTALLATION INSTRUCTIONS

##### 1.1 STEP ONE

Remove existing drip tray (PN 51-5075).

##### 1.2 STEP TWO

Install drain tubing adapter (PN 08-0083; 2 1/4" supplied, trim as necessary) to existing plastic (PVC) drain tube protruding from cabinet.

#### NOTES

Lubricating the inside of the drain tubing adapter (PN 08-0083) with soap water will make it easier to slip into place.

Total height from top of new drain tubing adapter to top of rim is 2 1/4 inches (see illustration).

##### 1.3 STEP THREE

Place new drip tray (PN 05-1147, supplied) into position. When installing new drip tray, use caution to insure drain from the new drip tray is properly inserted into the newly installed drain tubing adapter.

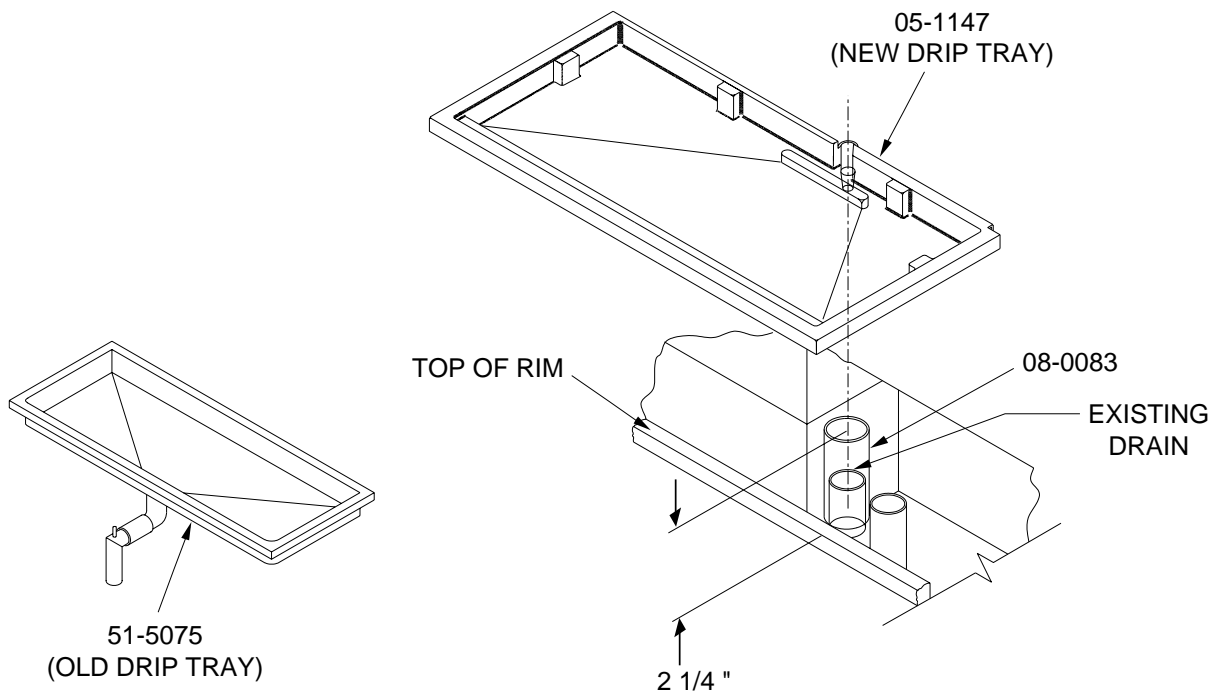

*Please refer to the Lancer web site ([www.lancercorp.com](http://www.lancercorp.com)) for information relating to Lancer Installation and Service Manuals, Instruction Sheets, Technical Bulletins, Service Bulletins, etc.*

# LANCER

6655 LANCER BLVD. • SAN ANTONIO, TEXAS 78219 USA • (210) 310-7000

FAX SALES

• NORTH AMERICA – 210-310-7245 • INTERNATIONAL SALES – 210-310-7242 • CUSTOMER SERVICE – 210-310-7242 •  
• LATIN AMERICA – 210-310-7245 • EUROPE – 32-2-755-2399 • PACIFIC – 61-8-8268-1978 •

FAX ENGINEERING: • 210-310-7096

"Lancer" is the registered trademark of Lancer • Copyright — 1996 by Lancer, all rights reserved.

DATE: 04/15/96  
P.N.: 28-0626